

**Whirlpool 30-INCH SET-IN
 SELF-CLEANING ELECTRIC RANGE
 Model RS660BXX**

use & care guide

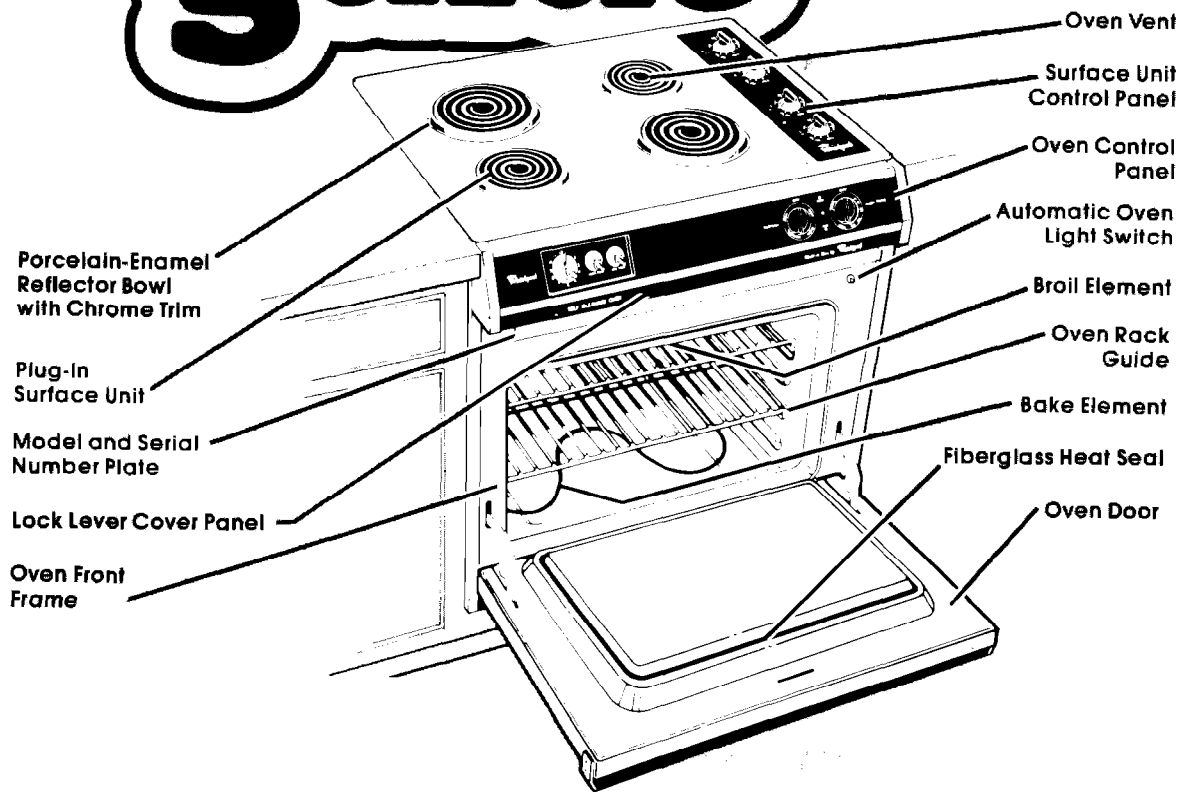

Copy Your Model and Serial Numbers Here

If you need service, or call with a question, have this information ready:

1. **Complete** Model and Serial Numbers (from the plate just behind the oven door).
2. Purchase or installation date from your sales slip.

Copy this information in these spaces. Keep this book, your warranty and the sales slip together in a handy place.

_____ Model Number

_____ Serial Number

_____ Purchase/Installation Date

_____ Service Company and Phone Number

See the "Cooking Guide" for important safety information.

Your responsibilities...

Proper installation and safe use of the range are your personal responsibilities. Read this "Use and Care Guide" and the "Cooking Guide" carefully for important use and safety information.

Installation

You must be sure your range is...

- installed and leveled in a cabinet and on a floor that will hold the weight;
- installed in a well-ventilated area protected from the weather;
- properly connected to the correct electric supply and grounding. (See "Installation Instructions.")

Proper use

You must be sure your range is...

- used only for jobs expected of home ranges;
- used only by people who can operate it properly;
- properly maintained.

Contents

	Page
Your Responsibilities	2
Installation	2
Proper Use	2
Safety	3
Using Your Range	4
Surface Unit Controls	4
Oven Controls	5
Baking	5
Resetting the Oven Temperature Control	5
Broiling	6
Oven Rack Positions	6
Setting the Clock	7
Minute Timer	7
Automatic MEALTIMER Clock	8
Oven Light	9
Oven Vent	9
Optional Rotisserie	9
Cleaning and Caring for Your Range	10
The Control Panel and Knobs	10
Surface Units and Reflector Bowls	10
Cleaning Chart	11
Using the Self-Cleaning Cycle	12
If You Need Service or Assistance	15
1. Before Calling for Assistance	15
2. If You Need Assistance	15
3. If You Need Service	15
4. If You Have a Problem	15

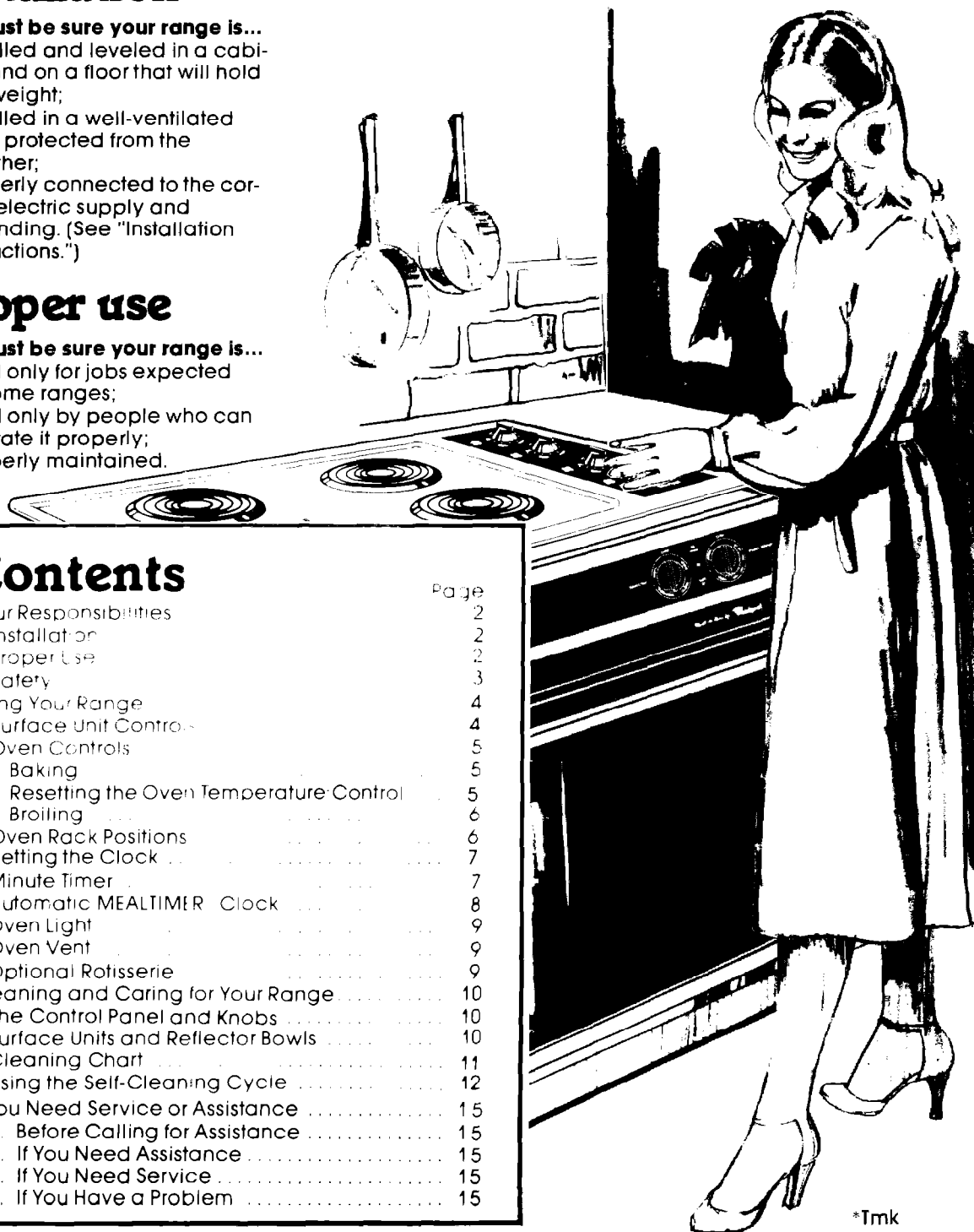

*Tmk

Safety



DO NOT allow children to use or play with the range.
DO NOT leave children unattended near the range.

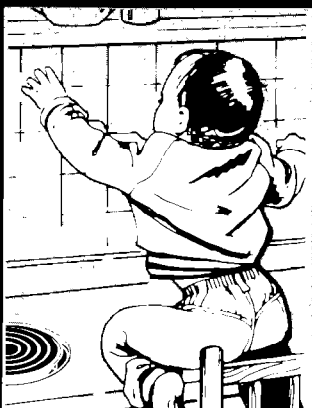

DO NOT store things children might want above the range.



Red surface units and oven heating elements are very hot, but dark units or elements can still be hot enough to burn severely.

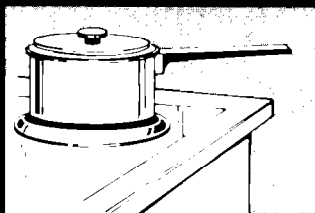

Keep pan handles turned in, but not over another surface unit.

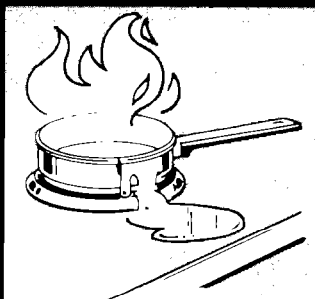

Make sure surface units are off when you are finished, and when you aren't watching.

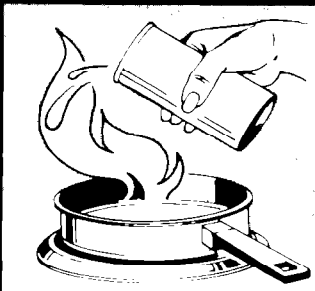

DO NOT use water on grease fires.



DO NOT line reflector bowls with foil. Shock or fire hazard can result.



DO NOT use a towel or other bulky cloth as a pot holder.

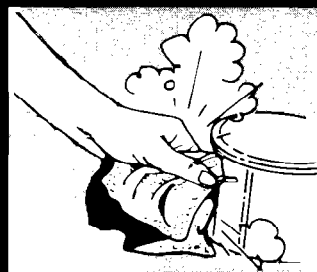

DO NOT use a wet pot holder. Steam burns can result.



DO NOT wear loose or hanging garments when using the range.

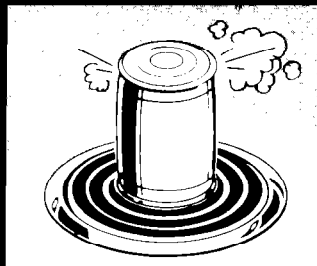

DO NOT heat unopened containers. They can explode.

Remove the Consumer Buy Guide label before using your range.

Using your range

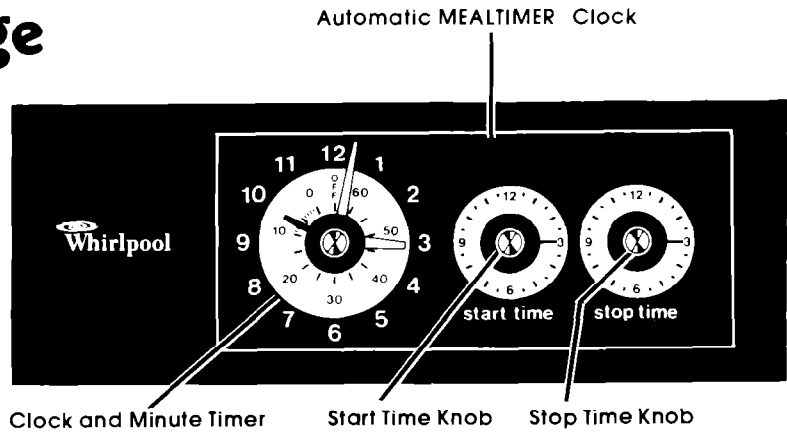
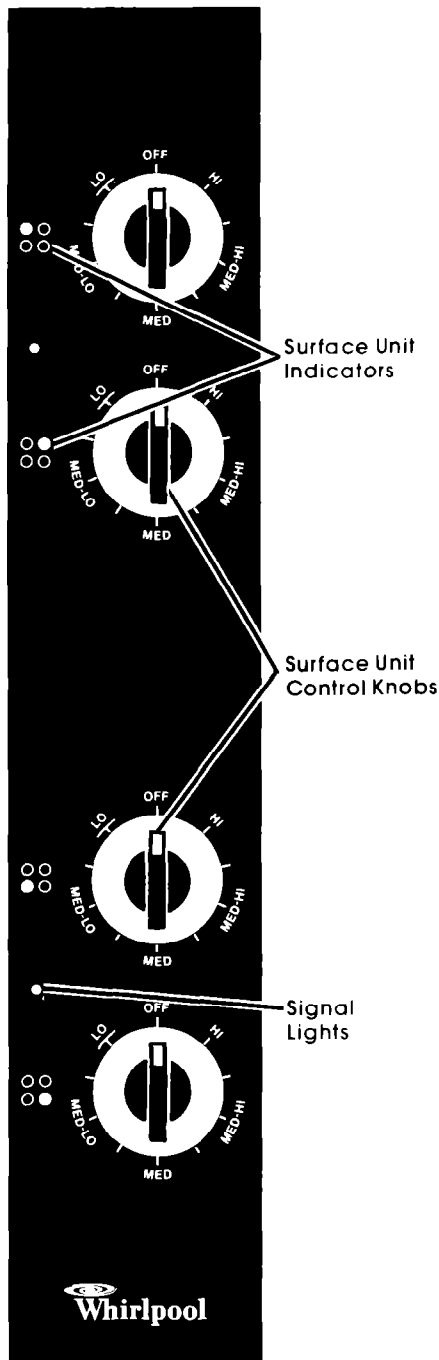

SURFACE UNIT CONTROLS

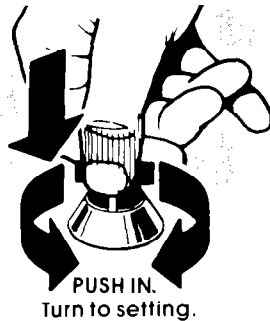

Control knobs **must be pushed in before turning** them to a setting. They can be set anywhere between HI and OFF.

One of the signal lights will glow when a surface unit is on. Be sure all lights are off when you are not cooking.

Until you get used to the settings, use the following as a guide.

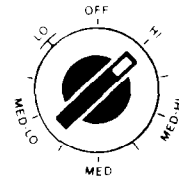

Use HI to start foods cooking or to bring liquids to a boil.

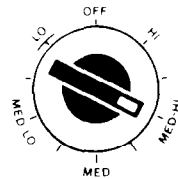

Use MED-HI to hold a rapid boil or to fry chicken or pancakes.

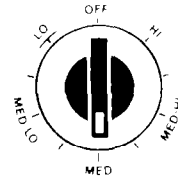

Use MED for gravy, puddings and icings or to cook large amounts of vegetables.

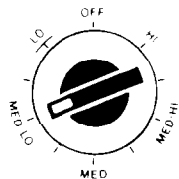

Use MED-LO to keep food cooking after starting it on a higher setting.

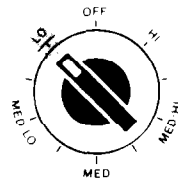

Use LO to keep food warm until ready to serve. Set the heat higher or lower within the LO band to keep food at the temperature you want.

SURFACE UNITS:

Element will be black during cooking if contact with bottom of pan is good. Element will not turn red if good contact is made.

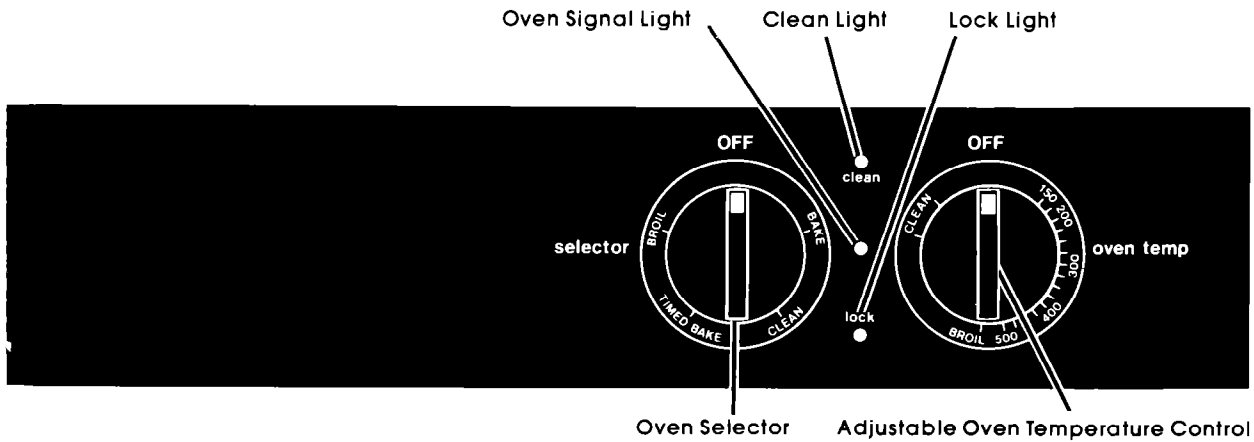

OVEN CONTROLS

BAKING

1. Put oven racks where you want them.
(See page 6 for suggestions.)
2. Set Oven Selector to BAKE.
3. Set Oven Temperature Control to the baking temperature you want.
4. Let the oven preheat until the Signal Light goes off.
5. Put food in the oven.
6. When done baking, turn both knobs to OFF.

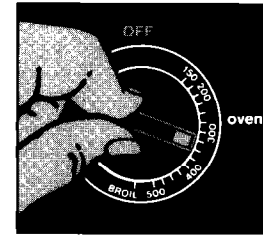
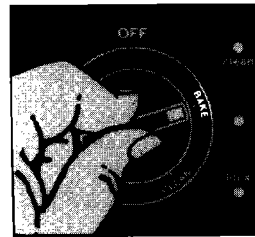

During baking, the elements will turn on and off to help hold the oven temperature at the setting. (The top element will never turn red, but will be hot.) The Signal Light will turn on and off with the elements.

RESETTING THE OVEN TEMPERATURE CONTROL

Does your new oven seem to be hotter or colder at the same settings than your old oven? The temperature setting in your old oven may have changed gradually over the years. The accurate setting of your new oven can seem different. If you think the oven temperature needs adjusting, follow these steps:

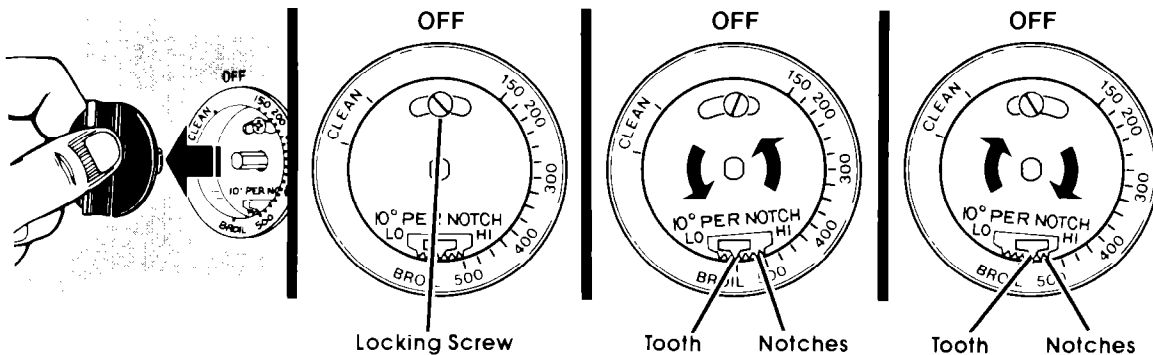

1. Pull out the center of the Oven Temperature Control.
2. Loosen the locking screw.
3. To lower the temperature, move black ring so tooth is closer to LO. Each notch equals about 10° F (5° C).
4. To raise the temperature, move black ring so tooth is closer to HI. Each notch equals about 10° F (5° C).

Tighten the locking screw. Replace the knob.

BROILING

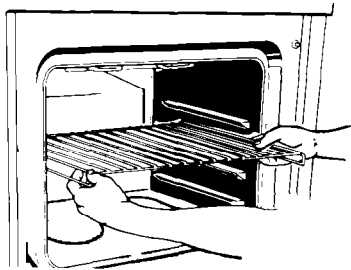

1. Place the rack where you want it for broiling. (See below for suggestions.)

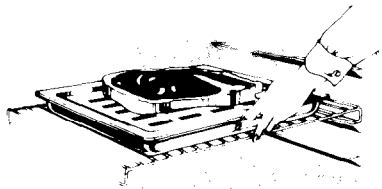

2. Put broiler pan and food on the rack.

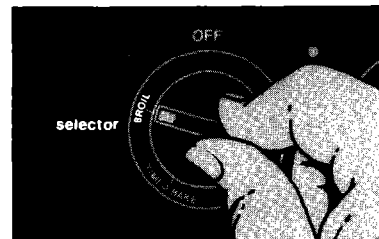

3. Set Oven Selector to BROIL.

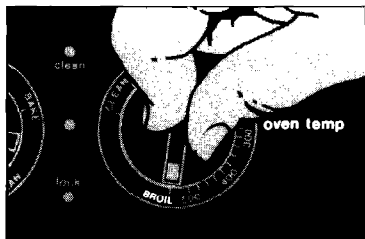

4. Set Oven Temperature Control to BROIL. (Set on a lower temperature for slower broiling. See below.)

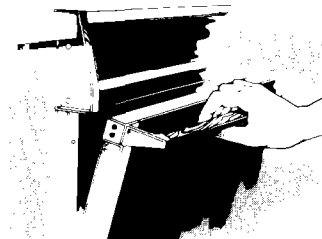

5. During broiling the oven door must be partly open. A built-in stop will hold it there.

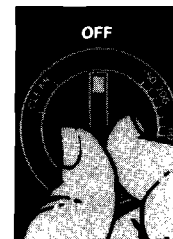
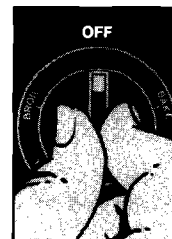

6. When broiling is done, turn both knobs to OFF.

Broiling can be slowed by setting the Oven Temperature Control to a setting lower than BROIL. When it's on BROIL, the broil element is on all the time. When it's on a temperature, the element turns off and on. The lower the temperature setting, the shorter are the times when the element is on.

The Oven Selector must be on BROIL and the door partly open for all broiling temperatures.

OVEN RACK POSITIONS

Position racks before turning on the oven.

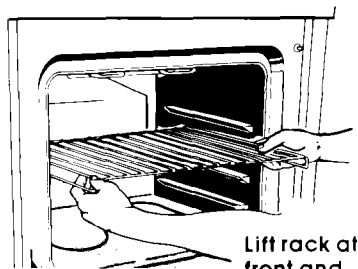

Lift rack at front and pull out.

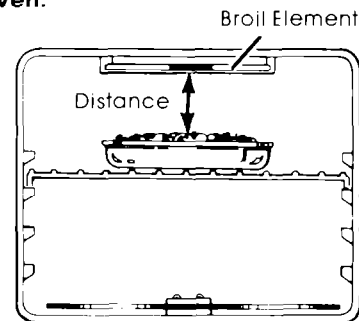
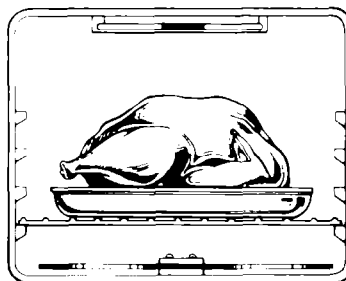

BAKING OR ROASTING

Food for baking or roasting should be placed in the center of the oven.

Always leave at least 1 1/2 to 2 inches (4-5 cm) between the sides of a pan and the oven wall and another pan. For more information, see the "Cooking Guide."

BROILING

Adjust the top rack so the food to be broiled is at a suggested distance from the broil element. (See page 7.) ALWAYS broil with the door open to the broil-stop.

Suggested oven-rack positions and broiling times for different kinds of meats.



Food	Description	Inches (cm) from top of food to Broil Element	Approximate Minutes – Selector set to BROIL	
			1st side	2nd side
Beef Steaks				
Rare	1" (2.5 cm)	3" (8 cm)	7-9	3-5
Medium	1" (2.5 cm)	3" (8 cm)	9-11	4-7
Well done	1" (2.5 cm)	3" (8 cm)	11-13	5-7
Beef Steaks				
Rare	1½" (4 cm)	4"-5" (10-13 cm)	13-15	6-8
Medium	1½" (4 cm)	4"-5" (10-13 cm)	17-19	8-10
Well Done	1½" (4 cm)	4"-5" (10-13 cm)	19-21	14-16
Hamburgers	½" (1 cm)	3" (8 cm)	6-8	4-5
Lamb Chops				
Medium	1" (2.5 cm)	3" (8 cm)	6-8	4-5
Ham slice, precooked or tendered	½"-1" (1-2.5 cm)	3" (8 cm)	6-8	4-5
Canadian Bacon	½" (1 cm)	3" (8 cm)	6	4
Pork Rib or Loin Chop	¾"-1" (2-2.5 cm)	4"-5" (10-13 cm)	15	10
Well done				
Chicken	2-3 lb. (1-1.5 kg) cut in half	7"-9" (18-23 cm)	25-30	10-12
Fish	whole	3" (8 cm)	11-16	9-14
	fillets	3" (8 cm)	7-8	5-7
Liver	½"-¾" (1-2 cm)	3" (8 cm)	3	3
Frankfurters		4"-5" (10-13 cm)	6-7	4-5

SETTING THE CLOCK

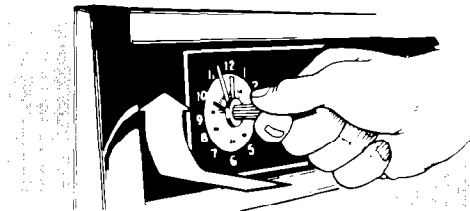

1. Push in Minute Timer Knob and turn clockwise until clock hands show the right time of day.

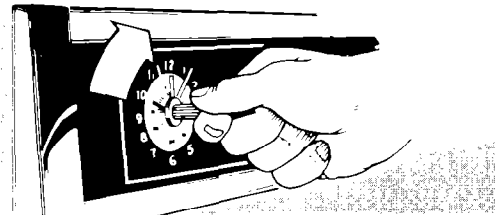

2. Let the Minute Timer Knob pop out. Turn clockwise until the Minute Timer hand points to OFF. If you push in on the knob, you will change the time of day.

USING THE MINUTE TIMER

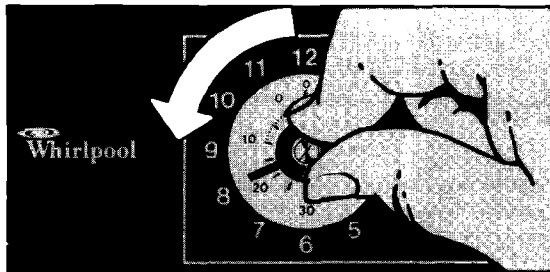

1. Without pushing it in, turn the Minute Timer Knob until the hand passes the setting you want.

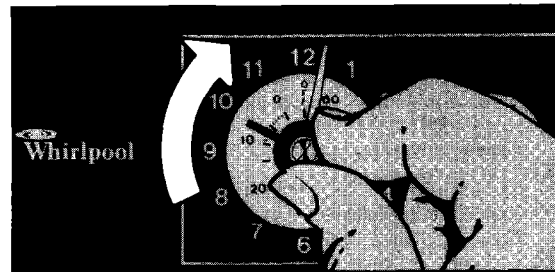

2. Turn the hand back to the setting you want.
3. When the set time is up, a buzzer will sound.
4. Turn the hand to OFF to stop the buzzing.

USING THE AUTOMATIC MEALTIMER* CLOCK

The Automatic MEALTIMER Clock is designed to turn the oven on and off at times you set...even when you are not around.

To start and stop baking automatically:

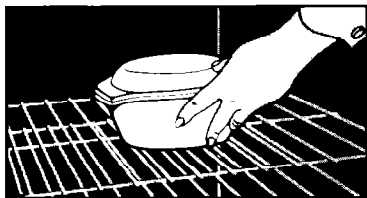

1. Put the racks where you want them and place the food in the oven.

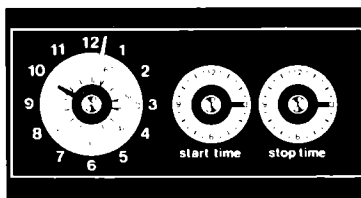

2. Make sure the clock is set to the right time of day.

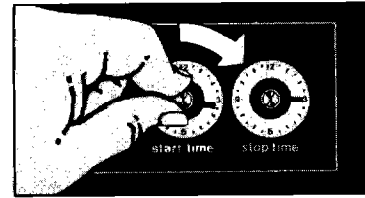

3. Push in and turn the Start Time Knob **clockwise** to the time you want baking to start.

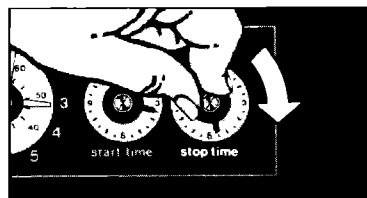

4. Push in and turn the Stop Time Knob **clockwise** to the time you want the oven to shut off.



5. Set the Oven Selector on **TIMED BAKE**.

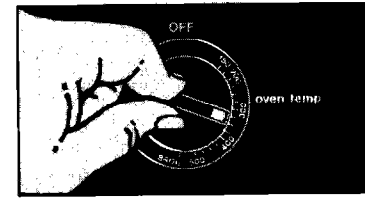

6. Set the Oven Temperature Control on the baking temperature you want.

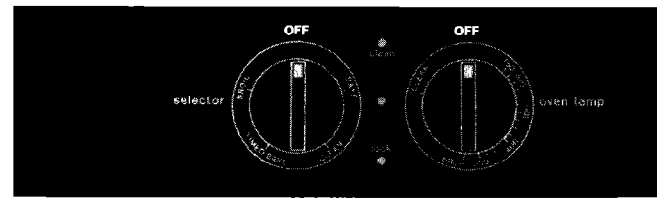

7. After baking is done, turn both knobs to OFF.
8. To stop the oven before the preset time, turn both knobs to OFF.

To stop baking automatically:

1. Put the racks where you want them and place the food in the oven.
2. Make sure the clock is set to the right time of day.
3. Push in and turn the Stop Time Knob **clockwise** to the time you want the oven to shut off.
4. Set the Oven Selector on **TIMED BAKE**.
5. Set the Oven Temperature Control on the baking temperature you want.
6. After baking is done, turn both knobs to OFF.
7. To stop the oven before the preset time, turn both knobs to OFF.

SPECIAL CAUTION:

Use foods that will not go bad or spoil while waiting for cooking to start. Avoid using dishes with milk or eggs, cream soups, cooked meats or fish, or any item with baking powder or yeast.

Smoked or frozen meats may be used; so can vegetables, fruits and casserole-type foods. Vegetables can be cooked in

a covered baking dish with about a half-cup (118 mL) of water for 1 to 1½ hours.

Any food that has to wait for cooking to start should be very cold or frozen before it is put in the oven. **MOST UNFROZEN FOODS SHOULD NEVER STAND MORE THAN TWO HOURS BEFORE COOKING STARTS.**

THE OVEN LIGHT

The oven light will come on when you open the oven door. It goes off when the door is closed.

To replace the light bulb:

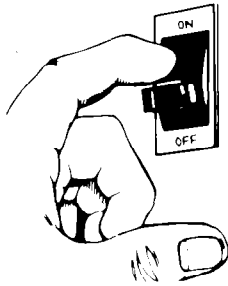

1. Turn off the electric power at the main power supply.

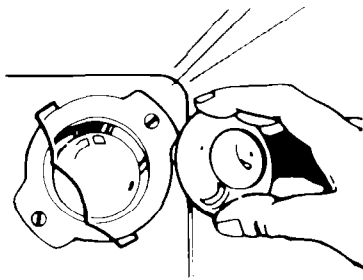

2. Remove the bulb cover by pulling out on the wire holder and moving it to the side.

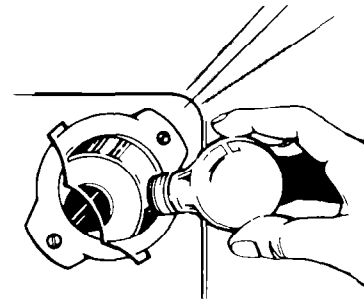

3. Remove the light bulb from its socket.

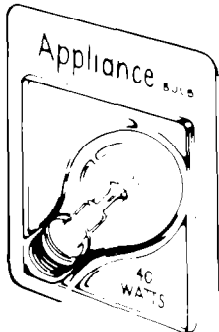

4. Replace the bulb with a 40-watt **appliance** bulb available from most grocery, variety and hardware stores.

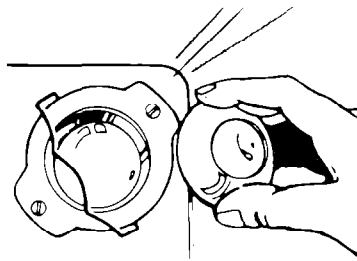

5. Replace the bulb cover and snap the wire holder in place. **The bulb must have this cover when the oven is being used.**

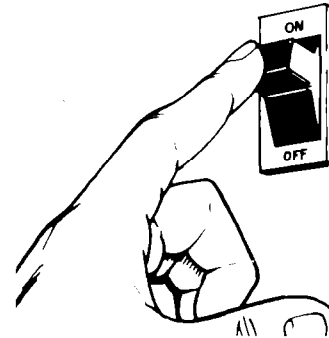

6. Turn electrical power back on at main power supply.

THE OVEN VENT

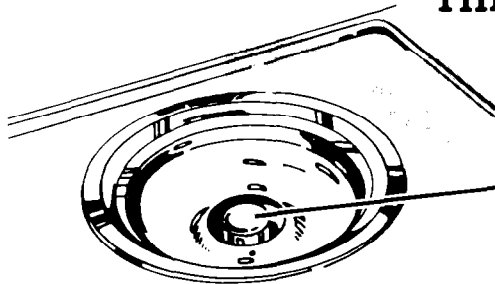

When the oven is on, hot air and moisture escape through a vent under the right rear surface unit. The vent is needed for air circulation in the oven.

Do not block the vent. Poor baking can result.

THE OPTIONAL ROTISSERIE

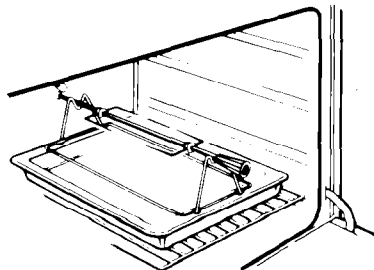

If you would like a rotisserie for your oven, you can order a kit (Part No. 261881) from your dealer. The kit includes easy installation instructions.

Cleaning and caring for your range

CONTROL PANELS AND KNOBS

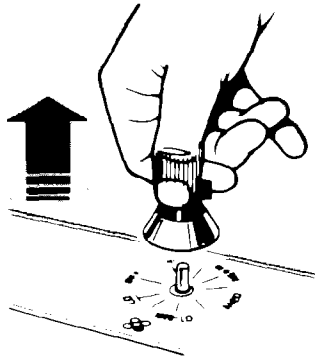

1. First make sure knobs are set on OFF then pull knob straight off.

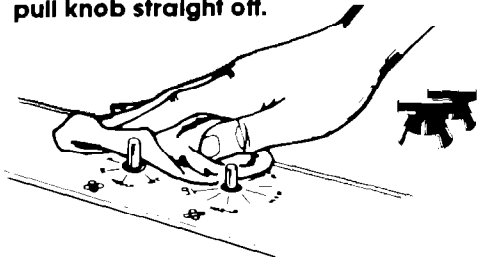

2. Use warm soapy water and a soft cloth to wipe the panel. Rinse and wipe dry.

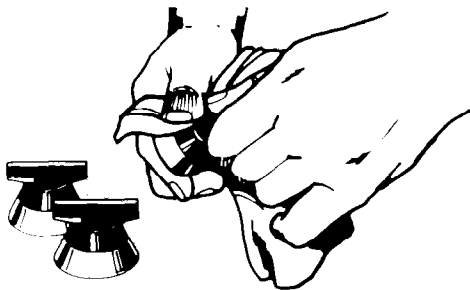

3. Wash knobs in warm soapy water. Rinse well and dry.

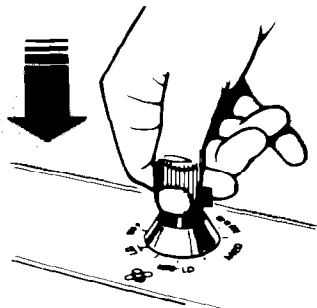

4. Push the knobs straight back on. Make sure they point to OFF.

SURFACE UNITS AND REFLECTOR BOWLS

REMOVING

1. Be sure surface units are OFF and COOL.

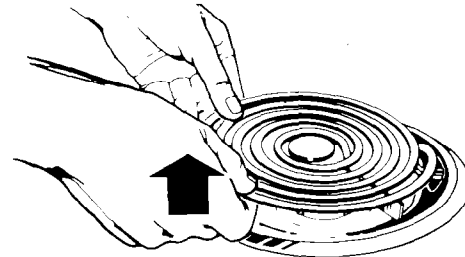

2. Lift the edge of the unit opposite the receptacle just enough to clear the reflector bowl.

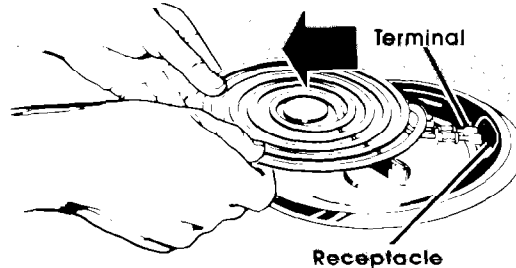

3. Pull the surface unit straight away from the receptacle.

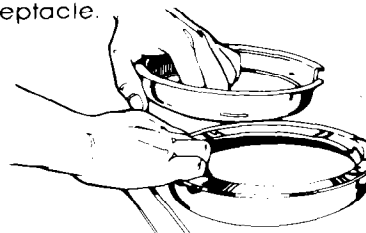

4. Lift out the reflector bowl and trim ring.

REPLACING

1. Be sure surface unit controls are OFF.

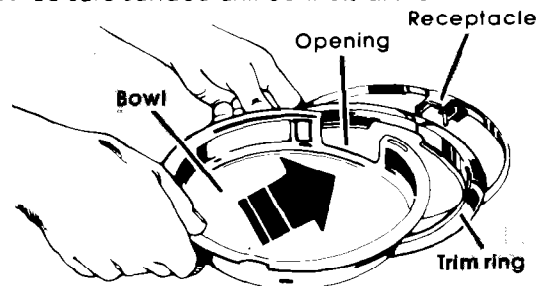

2. Line up opening in the reflector bowl and notch in trim ring with the surface unit receptacle.

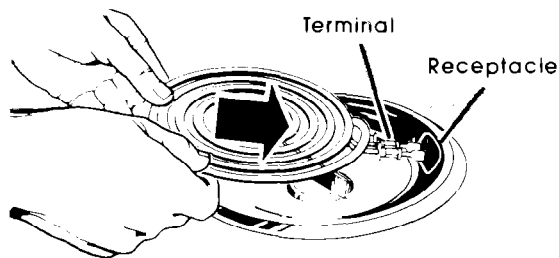

3. Hold the surface unit as level as possible with the terminal just started into the receptacle.

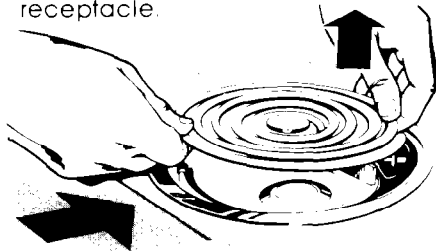

4. While pushing the surface unit terminal into the receptacle, lift a little on the edge of the unit nearest the receptacle.

5. When the terminal is pushed into the receptacle as far as it will go, the surface unit will fit into the trim ring.

Reflector bowls reflect heat back to the utensils on the surface units. They also help catch spills. When they are kept clean, they reflect heat better and look new longer.

If a trim ring gets discolored, some of the utensils used may not be flat enough. Or some may be too large for the surface unit. In either case, some of the heat that is meant to go into or around a utensil goes down and heats the trim ring. This extra heat can discolor it.

DO NOT LINE THE REFLECTOR BOWLS WITH FOIL. Use of foil can cause shock or fire hazard.

CLEANING CHART

PART	WHAT TO USE	HOW TO CLEAN
Outside of range	Soft cloth, warm soapy water Nylon or plastic scouring pad for stubborn spots	<ul style="list-style-type: none"> Wipe off regularly when range is cool. Do not allow food containing acids (such as vinegar, tomato, lemon juice or milk) to remain on surface. Acids will remove the glossy finish. Do not use abrasive or harsh cleansers.
Surface units	No cleaning required	<ul style="list-style-type: none"> Spatters or spills will burn off. Do not immerse in water.
Control knobs	Warm, sudsy water and bristle brush	<ul style="list-style-type: none"> Wash, rinse and dry well. Do not soak.
Porcelain-enamel reflector bowls	Automatic dishwasher or warm, soapy water Self-Cleaning Oven cycle	<ul style="list-style-type: none"> Wipe out excess spills. Wash with other cooking utensils for routine cleaning. Place upside down on oven racks in oven during Self-Cleaning Oven cycle.
Chrome trim rings	Automatic dishwasher or warm, soapy water or plastic scrubbing pad	<ul style="list-style-type: none"> Wash with other cooking utensils. Do not place in Self-Cleaning Oven.
Porcelain-enamel broiler pan and grid	Warm, soapy water or soapy steel wool pads	<ul style="list-style-type: none"> Wash with other cooking utensils. Do not place in Self-Cleaning Oven.
Surface unit control panel	Warm, soapy water	<ul style="list-style-type: none"> Wash, rinse and dry with soft cloth.
Oven control panel	Warm, soapy water Commercial glass cleaner	<ul style="list-style-type: none"> Wash, rinse and dry with soft cloth. Follow directions provided with cleaner.
Oven racks	Self-Cleaning Oven cycle Warm, soapy water or soapy steel wool pads	<ul style="list-style-type: none"> Leave in oven during Self-Cleaning cycle. Wash, rinse and dry. Use soapy steel wool pads for stubborn areas.
Oven door	Warm, soapy water or plastic scrubbing pad Commercial glass cleaner	<ul style="list-style-type: none"> Make certain oven is cool. Wash, rinse and dry well with soft cloth. Follow directions provided with cleaner.
Self-Cleaning Oven	For areas outside Self-Cleaning area use warm, soapy water or soapy steel wool pads	<ul style="list-style-type: none"> Clean before using Self-Cleaning cycle to prevent burn-on of soil. Follow directions given on page 12, "Using the Self-Cleaning Cycle."

**Do not use commercial oven cleaners.
Do not use foil to line the bottom of your Self-Cleaning Oven.**

USING THE SELF-CLEANING CYCLE

The self-cleaning cycle uses **very high heat** to burn away soil. Before you start, make sure you understand exactly how to use the cycle safely.

BEFORE YOU START

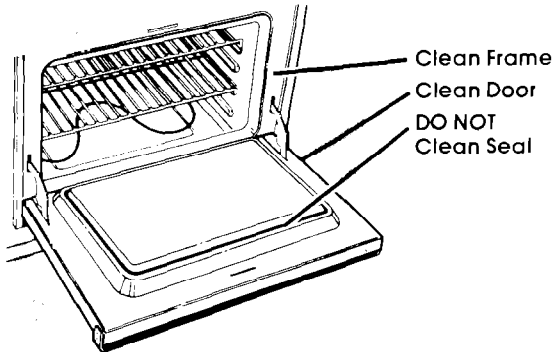

1. Clean areas that may not be cleaned during the cycle. Use hot water and detergent or a soapy steel-wool pad on...
 - the frame around the oven
 - the inside of the door, especially the part outside the oven seal.

DO NOT try to clean the fiberglass seal. **DO NOT** move it or bend it.

2. Remove any pots or pans you may have stored in the oven. They can't stand the high heat.
3. Wipe out any loose soil or grease. This will help reduce smoke during the cleaning cycle.
4. Make sure the motor socket cover is closed if your oven has a rotisserie.
5. Put oven racks on the top two guides. **Put two reflector bowls upside down on each rack.** They should not touch each other or the oven walls.

Chrome trim rings must not be cleaned in the oven. They will become discolored. High heat will also discolor oven racks. See special tips on page 14.

SPECIAL CAUTIONS

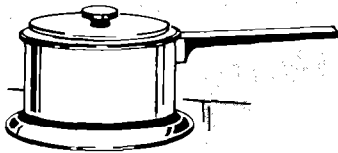

DO NOT block the vent during the cleaning cycle. Air must move freely for best results.

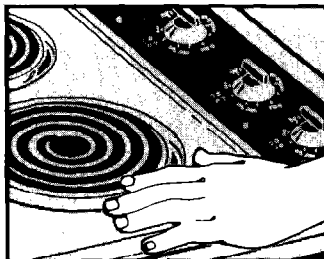

DO NOT touch the range during the cleaning cycle...it can burn you.

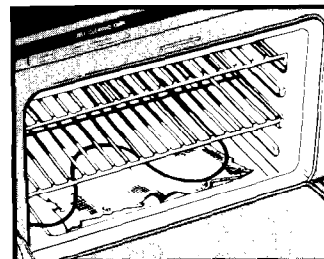

DO NOT use foil or other liners in the oven. During the cleaning cycle, foil can burn or melt.

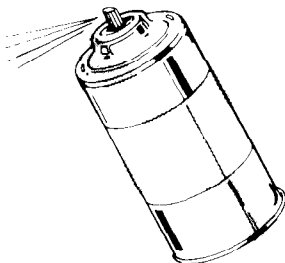

DO NOT use commercial oven cleaners in your oven. Damage to the porcelain finish may occur.

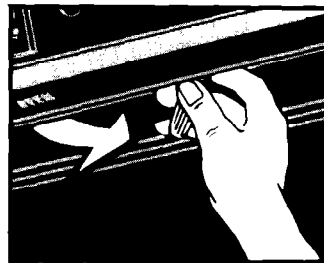

DO NOT force the Lock Lever. The lever is designed to stay locked until the oven is cool enough to safely open.

SETTING THE CONTROLS

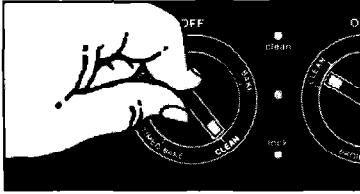

1. Set the Oven Selector to CLEAN.

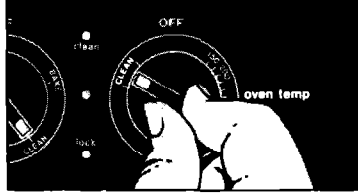

2. Set the Oven Temperature Control to CLEAN.

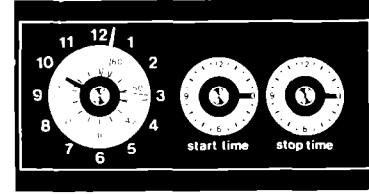

3. Make sure the clock and start and stop time dials all have the right time of day.

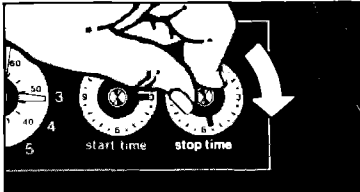

4. Push in the Stop Time Knob and turn the hand clockwise about two or three hours. (Two hours for light soil; three or more for heavier soil.)

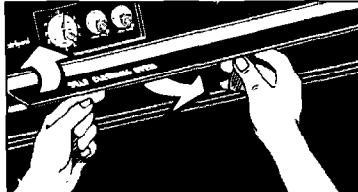

5. Lift the panel between the oven door and control panel.

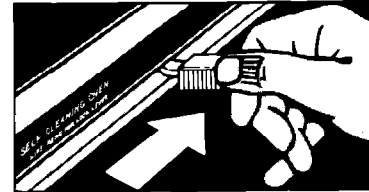

6. Move the Lock Lever *all the way to the right*. The Clean Light will come on only when the lever is all the way over.

DO NOT TOUCH THE RANGE DURING THE CLEANING CYCLE. IT CAN BURN YOU.

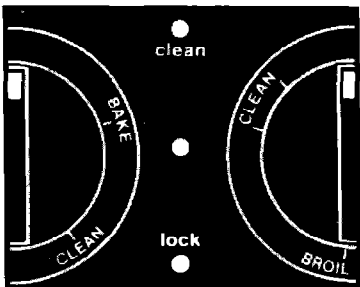

7. The Lock Light comes on when the oven gets above normal baking temperatures. The Lock Lever can't be moved when the Lock Light is on.

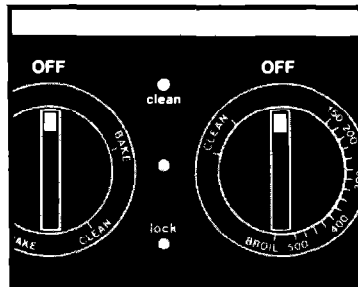

8. When the Lock Light goes off, turn the Oven Selector and Oven Temperature Control to OFF.

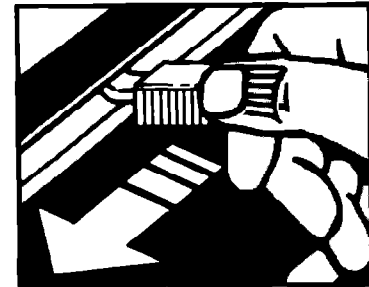

9. Move the Lock Lever back to the left. **Do not force it.** Wait until it will move easily. This turns off the Clean Light.

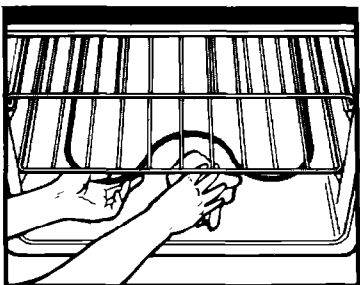

10. **After the oven is cool,** wipe off any residue or ash with a damp cloth. If needed, touch up spots with cleanser or soapy steel-wool pad.

SPECIAL TIPS

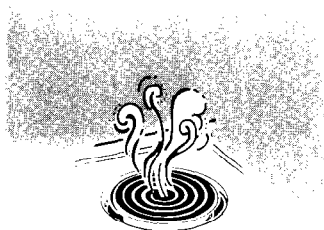

1. Keep the kitchen well ventilated during the cleaning cycle to help get rid of normal heat odors and smoke.

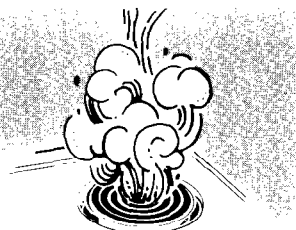

2. Clean the oven before it gets heavily soiled. Cleaning a very soiled oven takes longer and results in more smoke than usual.

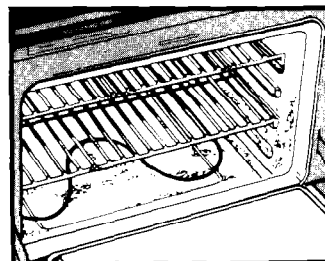

3. If the cleaning cycle doesn't get the oven as clean as you expected, the cycle may not have been set long enough. Set the cleaning time longer for heavier soil.

4. Oven racks lose their shine, discolor and become harder to slide on their guides when they are left in the oven during the cleaning cycle. To make them slide easier, polish the edges of the racks and rack guides with a soapy steel-wool pad, rinse well, and wipe on a thin coat of salad oil.

5. To stop the cleaning cycle after it has started:

- Turn the Stop Time Knob clockwise until the hand points to the right time of day.
- Turn the Oven Selector and Oven Temperature Control to OFF.
- When the oven cools, move the Lock Lever back to the left. DO NOT FORCE IT. Wait until it moves easily.

HOW IT WORKS

During the self-cleaning cycle, the oven gets much hotter than it does for baking or broiling...approximately 875° F (468° C). This heat breaks up grease and soil, and burns it off.

The graph shows approximate temperatures and times during a self-cleaning cycle set for two hours.

SELF-CLEANING CYCLE – TWO HOUR SETTING

(Approximate Temperatures and Times)

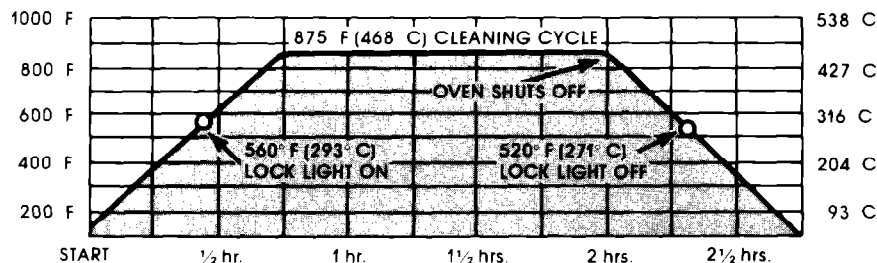

Notice that the heating stops when the two-hour setting is up, but that it takes a while longer for the oven to cool down enough to unlock.

If you need service or assistance, we suggest you follow these four steps:

1. Before calling for assistance...

Performance problems often result from little things you can find and fix yourself without tools of any kind.

If nothing operates:

- Is the range correctly wired to a live circuit with the proper voltage? (See **Installation Instructions**.)
- Have you checked the main fuse or circuit-breaker box?

If the oven will not operate:

- Is the Oven Selector turned to a setting (BAKE or BROIL, but not TIMED BAKE)?
- Is the Oven Temperature Control turned to a temperature setting?

If surface units will not operate:

- Have you checked the main fuse or circuit-breaker box?
- Are surface units plugged in all the way?
- Do the control knobs turn?

If surface unit control knob or knobs will not turn:

- Did you push in before trying to turn?

If the Self-Cleaning Cycle will not operate:

- Are the Oven Selector and the Oven Temperature Control set to "CLEAN?"
- Does the Start Time Dial show the correct time of day?
- Is the Stop Time Dial set ahead to the time you want the cleaning cycle to stop?
- Is the Lock Lever all the way to the right? (The Clean Light will come on.)

If cooking results aren't what you expect:

- Is the range level?
- Are you using pans recommended in the **Cooking Guide**?
- If baking, have you allowed 1½ to 2 inches (4-5 cm) on all sides of the pans for air circulation?
- Does the oven temperature seem too low or too high? (See page 5 to reset the Oven Temperature Control.)
- Have you preheated the oven as the recipe calls for?
- Are the pans the size called for in the recipe?
- Are you following a tested recipe from a reliable source?
- Do the cooking utensils have smooth, flat bottoms?
- Do the cooking utensils fit the surface unit being used?

See the **Cooking Guide** for more information on cooking problems and how to solve them.

2. If you need assistance* ...

Call the Whirlpool COOL-LINE® service assistance telephone number. Dial free from:

Continental U.S. (800) 253-1301
Michigan (800) 632-2243
Alaska & Hawaii (800) 253-1121

and talk with one of our trained Consultants. The Consultant can instruct you in how to obtain satisfactory operation from your appliance or, if service is necessary, recommend a qualified service company in your area.

3. If you need service* ...



Whirlpool has a nationwide network of franchised TECH-CARE® Service Companies. TECH-CARE service technicians are trained to fulfill the product warranty and provide after-

warranty service, anywhere in the United States. To locate TECH-CARE service in your area, call our COOL-LINE service assistance telephone number (see Step 2) or look in your telephone directory Yellow Pages under:

APPLIANCES—HOUSEHOLD— MAJOR—SERVICE & REPAIR	OR	ELECTRICAL APPLIANCES— MAJOR—REPAIRING & PARTS
WHIRLPOOL APPLIANCES FRANCHISED TECH-CARE SERVICE		WHIRLPOOL APPLIANCES FRANCHISED TECH-CARE SERVICE
SERVICE COMPANIES		
XYZ SERVICE CO 123 Maple	999-9999	XYZ SERVICE CO 123 Maple
	OR	
WASHING MACHINES, DRYERS & IRONERS—SERVICING		
WHIRLPOOL APPLIANCES FRANCHISED TECH-CARE SERVICE		
SERVICE COMPANIES		
XYZ SERVICE CO 123 Maple	999-9999	

4. If you have a problem* ...

Call our COOL-LINE service assistance telephone number (see Step 2) and talk with one of our Consultants, or if you prefer, write to:

Mr. Guy Turner, Vice President
Whirlpool Corporation
Administrative Center
2000 US-33 North
Benton Harbor, MI 49022

If you must call or write, please provide: model number, serial number, date of purchase, and a complete description of the problem. This information is needed in order to better respond to your request for assistance.



FSP is a registered trademark of Whirlpool Corporation for quality parts. Look for this symbol of quality whenever you need a replacement part for your Whirlpool appliance.

FSP replacement parts will fit right and work right, because they are made to the same exacting specifications used to build every new Whirlpool appliance.



Benton Harbor, Michigan. Automatic Washers. Clothes Dryers. Freezers. Refrigerator-Freezers. Ice Makers. Dishwashers. Built-in Ovens and Surface Units. Ranges. Microwave Ovens. Compactors. Room Air Conditioners. Dehumidifiers. Central Heating and Air Conditioning Systems.